



INVERTER GENERATOR

MODEL: SIG2000

OPERATOR'S MANUAL

ORIGINAL INSTRUCTIONS

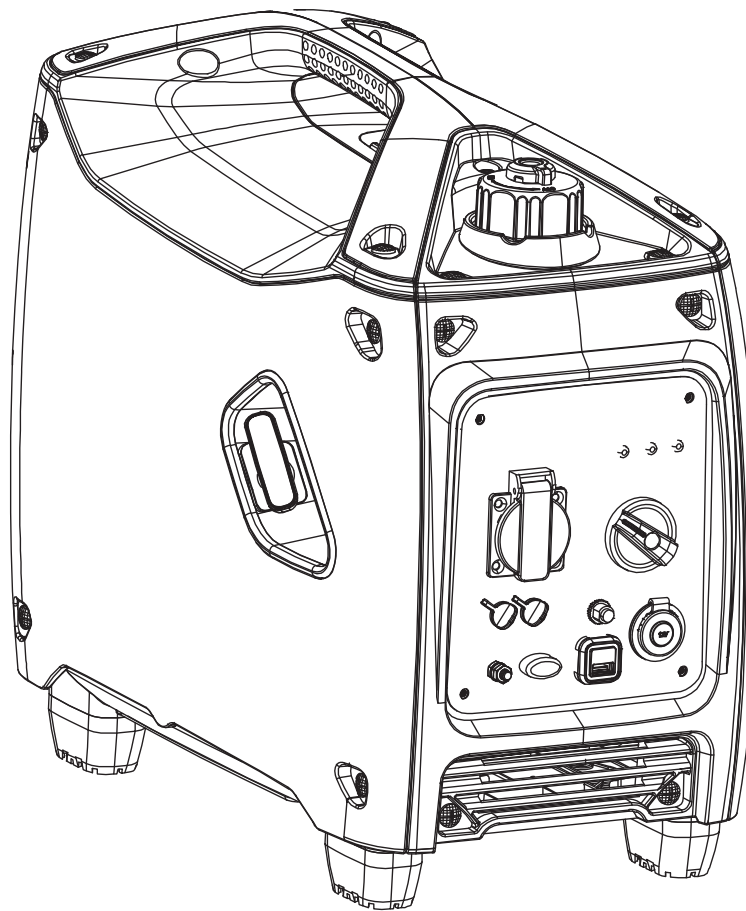

The picture is only for your reference

TABLE OF CONTENTS

Introduction	3
Product Specifications.....	3
Parts Ordering / Customer Service.....	3
Safety Rules	4
Safety Symbols	4
Safety Instructions	4
Features	7
Control Panel Functions	8
ON/OFF Start Switch and Choke.....	8
Indicator Lights.....	8
DC Circuit Breaker.....	9
Engine ECO Control.....	9
Parallel Outlets.....	9
Fuel Cap Air Vent.....	10
Ground Terminal.....	10
Assembly	11
Connecting Generator to an Electrical System.....	11
Adding Fuel.....	11
Adding / Checking Engine Oil	12
Operation	13
Grounding the Generator	13
How to Start Engine.....	13
How to Stop Engine.....	14
How to Attach Electronic Devices.....	14
Charging a 12 Volt Battery.....	15
AC Parallel Operation.....	16
Don't Overload Generator.....	17
Wattage Reference Guide.....	17
Maintenance	18
Maintenance Schedule	18
Checking Spark Plug	19
Changing Oil	20
Air Filter.....	21
Checking Muffler and Spark Arrester.....	21
Fuel Filter	22
Storage	22
Troubleshooting	24
Diagrams	25
EC DECLARATION OF CONFORMITY	26
NOISE	27

INTRODUCTION

Thank you for purchasing this superior quality portable generator . When operating and maintaining this product as instructed in this manual, your generator will give you many years of reliable service.

Product Specifications:

This generator is an engine-driven, revolving field, alternating current (AC) portable generator. It is designed to supply electrical power to operate tools, appliances, camping equipment, lighting, or serve as a back up power source during power outages.

Generator specification

Model	SIG2000
Voltage	230V
Frequency	60Hz
Power(COP)	1.6kw
Power(Max.)	1.8kw
Cigaratte Outlet	12V/8A
Parallel Outlet	YES
Engine type	4 Stroke/ Single Cylider/ OHV
Displacemnt	79cc
Fuel tank capacity	4.0L
Engine Oil Capacity	0.35L
Starting Type	Recoil start

SAFETY RULES

Safety Symbols



Indicates a potentially hazardous situation which could result in serious injury or death if not avoided.



Indicates a potentially hazardous situation which could result in damage to equipment or property.



Injury or damage



Read manual before use



Wear noise protection



Toxic fumes



Risk of fire



Risk of explosion



Risk of electric shock



Hot surface



Lifting hazard

Safety Instructions

The manufacturer cannot anticipate every possible hazardous circumstance that the user may encounter. Therefore, the warnings in this manual, on tags, and on affixed decals are not all-inclusive. To avoid accidents, the user must understand and follow all manual instruction and use common sense.



Read and understand this manual in its entirety before operating this generator. Improper use of this generator could result in serious injury or death.



Do not operate indoors or in a confined space preventing dangerous carbon monoxide gas from dissipating.

- Using a generator indoors **WILL KILL YOU IN MINUTES!**
- Carbon monoxide gas is a poisonous, odorless gas that can cause headache, confusion, fatigue, nausea, fainting, sickness, seizures, or death. If you start to experience any of these symptoms, **IMMEDIATELY** get fresh air and seek medical attention.
- Never use indoors, in a covered area, or in a confined space, even if doors and windows are open.
- Install a battery operated carbon monoxide alarm near bedrooms.
- Keep exhaust from this unit from entering a confined area through windows, doors, vents, or other openings.
- When working in areas where vapors could be inhaled, use a respirator mask according to all of its instructions.



Engine exhaust contains chemicals that lead to cancer and cause birth defects.

- Always wash hands after handling generator.

SAFETY RULES



WARNING

Never exceed generators wattage / amperage capacity. This could damage the generator and / or connected electrical devices.

- Check operating voltage and frequency requirements of all electrical devices prior to plugging them into the generator.



WARNING

Never start or stop engine with electrical devices plugged in to the receptacles. Failure to do so could damage the generator and / or connected electrical devices.

- Always start the engine and let it stabilize before connecting any electronic devices.
- Disconnect all electronic devices before stopping the engine.



WARNING

Starter and other moving parts can catch on clothing, jewelry, and hair.

- Do not wear loose clothing or gloves.
- Remove jewelry or anything else that could be caught in moving parts.
- Tie back or wear protective head covering to contain long hair.



WARNING



Keep engine away from flammable objects and other hazardous materials.

- The fuel and its vapors used to power this unit are highly flammable and could explode resulting in serious injury or death.
- Never fill or drain fuel tank indoors.
- Never overfill fuel tank. If fuel spills, move the unit at least 30 feet away from the spill and wipe up any remaining fuel on the unit before starting the engine.
- Never smoke while operating or fueling this unit.
- Never operate or store this unit near an open flame, heat, or any other ignition source.
- Generator should have at least 5 feet of clearance from buildings or other equipment during operation.
- Keep engine free of grass, leaves, or grease which are flammable.
- When adding or draining fuel, unit should be turned off for at least 2 minutes to cool before removing fuel cap. If unit has been running then the fuel cap is under pressure, remove slowly.
- To keep fuel from spilling, secure unit so it cannot tip while operating or transporting.
- When transporting unit, disconnect the spark plug wire and make sure the fuel tank is empty with the 3 in 1 switch is turned to the off position.



WARNING

Pull cord recoils rapidly and pulls arm towards engine faster than you can let go which could result in injury.

- To avoid recoil, pull starter cord slowly until resistance is felt, then pull rapidly.



WARNING



Avoid contacting hot areas of this unit.

- Use caution around the muffler, cylinder, and other engine parts as they can be extremely hot.
- Allow hot components to cool before touching.

SAFETY RULES

WARNING



This generator produces a very high voltage which could result in burn or electrocution causing serious injury or death.

- Never handle the generator, electronic devices, or any cord while standing in water, while barefoot, or when hands or feet are wet.
- Always keep the generator dry. Never operate generator in rain or under wet conditions.
- Use a ground fault circuit interrupter (GFCI or RCD) in a damp or highly conductive area, such as metal decking or steel work.
- Never plug electronic devices into generator having frayed, worn, or bare wires. Never touch bare wires or make contact with receptacles.
- Never permit a child or unqualified person to operate generator. Keep children a minimum of 10 feet away from the generator at all times.
- If using the generator for back up power, notify the utility company.
- If connecting generator to a building's electrical system for standby power, you must use a qualified electrician to install a transfer switch. Failure to isolate the generator from the power utility could result in serious injury or death to electric utility workers.

WARNING



Generator must be properly grounded to prevent electrocution.

- Only operate generator on a level surface.
- Always connect the nut and ground terminal on the frame to an appropriate ground source.

WARNING

Never modify this unit in any way or modify governed speed.

- Increasing governing speed is dangerous which can result in personal injury and / or damaged equipment.
- Decreasing governing speed adds an excessive load and can damage equipment.
- Only when operating at the preset governing speed will this generator supply the correct rated frequency and voltage.

WARNING

Only use this unit as it is intended or serious injury or death could result.

- Do not bypass any safety device. Moving parts are covered with guards. Make sure all protective covers are in place.
- Never transport or make adjustments to this unit while it is running.
- Never insert objects through cooling slots.

WARNING

Never operate this unit if there are any broken or missing parts and only use our Equipment replacement parts specifically designed for this unit.

- Improper treatment of generator can damage the unit and shorten its life.
- Always repair this unit as specified in this manual. If you have any questions contact your dealer or consult a qualified service center.
- Shut generator off if electrical outpost is missing, unit vibrates excessively or begins to smoke, spark or emit flames.

PROP 65 WARNING: This product contains chemicals known to the state of California to cause cancer and birth defects or other reproductive harm.

FEATURES

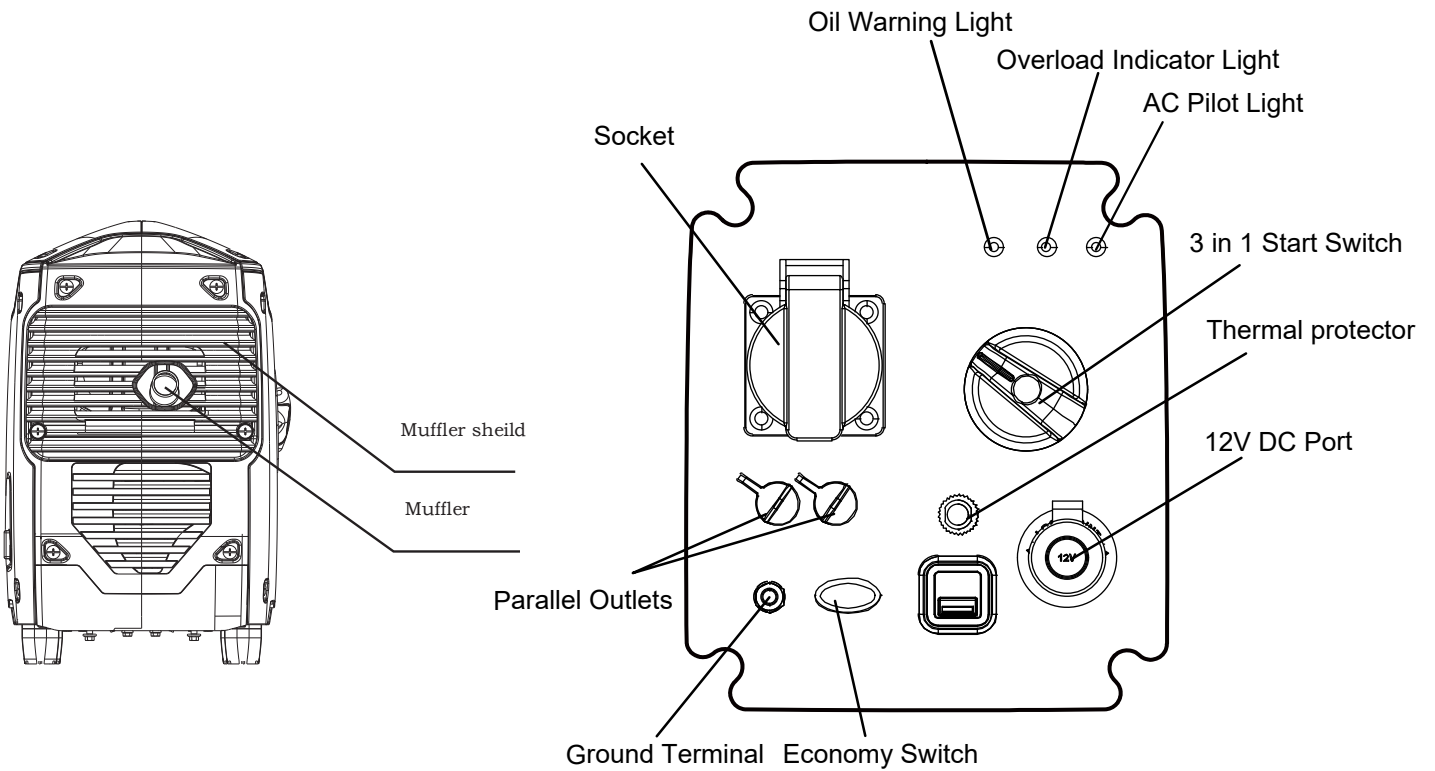
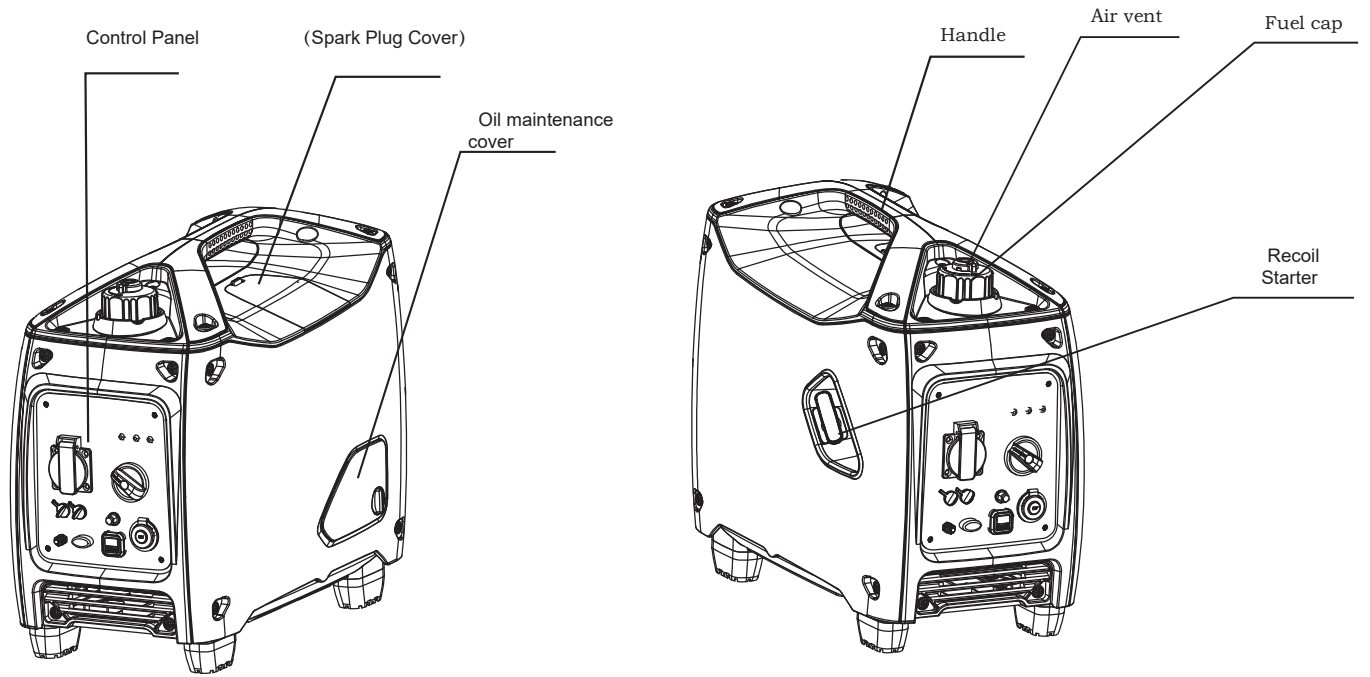

CONTROL PANEL FUNCTIONS

ON/OFF Start Switch and Choke

Start Switch “OFF”

When the Start Switch is in the “OFF” position the fuel valve is switched off and the engine will not run.

Start Switch “CHOKE”

When the Start Switch is in the “CHOKE” position the fuel valve is switched on and the engine can be started.

Start Switch “ON”

When the Start Switch is in the “ON” position the fuel valve is switched on and the engine can run.

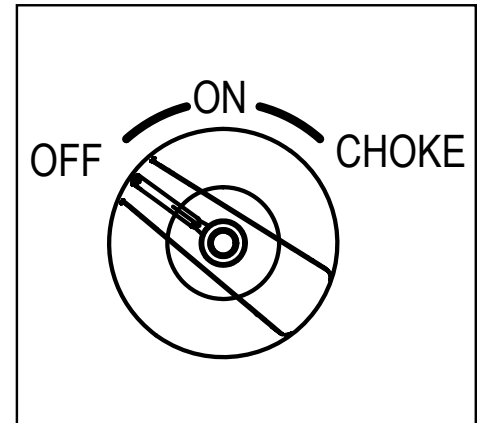

Note: The Choke is not required to start a warm engine

Oil Warning Indicator Light

When the oil falls below the minimum level, the oil warning indicator light comes on and the engine stops automatically. The engine will not



Note: If the oil warning indicator light does not come on and the engine stalls, turn the Start Switch to “ON” and pull the recoil starter.

Engine Overload Indicator Light

If the engine overload indicator light comes on, the generator’s wattage / amperage capacity has been exceeded by connected electrical devices or by a power surge. When this occurs, the green AC Pilot Indicator Light will go off. The engine will continue to run, but the red Engine Overload Indicator Light will stay on and power will no longer be supplied to connected electronic devices.

How to Correct

1. Disconnect any electronic devices then stop the engine.
2. Reduce the total wattage of connected electronic devices until it is within the generator’s rated output.
3. Inspect the Air Inlet and Control Panel for any blockage. Remove blockage if found.
4. Restart Engine.

Note: The engine overload indicator light may turn on for a few seconds when attaching a load due to a power surge. This is normal.

CONTROL PANEL FUNCTIONS

AC Pilot Indicator Light

The green AC Pilot Indicator Light comes on when the engine starts and generates power.



DC Circuit Breaker

When the DC Circuit Breaker is in the "ON" position, the generator is able to supply power to connected electronic devices. When the DC Circuit Breaker is in the "OFF" position, the generator will no longer supply power. The DC Circuit Breaker automatically turns "OFF" when connecting electronic devices to the generator that exceed the generator's rated output. If the DC Circuit Breaker turns off, reduce the load of connected electronic devices until the load is within the specified rated output. To re-establish power, return the DC Circuit Breaker back to the "ON" position.



CAUTION

If the DC Circuit Breaker turns off again, stop using the generator immediately and consult our dealers.

Engine ECO Control

- When the Engine ECO switch is turned to the "ON" position, the economy control unit automatically determines the generator's proper engine speed based on the connected electronic load. This results in superior fuel economy and reduces noise.
- When the ECO switch is turned to the "OFF" position, the engine runs at the rated speed of 4,850 r/min.

ECO switch

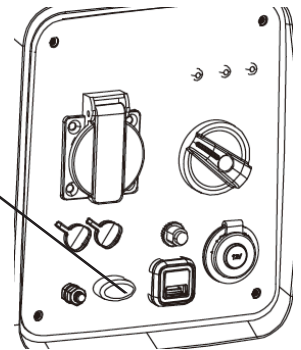

Note: The ECO switch must be turned to the "OFF" position when using electronic devices that require a large starting current, such as a compressor.

Parallel Outlets

Located just above the Ground Terminal, the generator's Parallel Outlets enable a user to run two D2000iS generator's simultaneously. This operation requires special cables. When operating parallel generators, the rated output is 3.0Kva and the rated current is 25A/120V. For cables and instructions consult SGS Engineering for a PARALLEL OPERATION CABLE KIT.



WARNING

Never connect generators that are different models.

- Only connect this generator to another D2000iS Standard Generator or D2000iS Companion Generator
- Only use brands approved parallel operation cable kit to connect generators

CONTROL PANEL FUNCTIONS

Fuel Cap

Turn counter-clockwise to remove the fuel cap

Fuel Cap Air Vent

The fuel cap is equipped with an air vent to stop fuel from flowing to the carburettor. The Air Vent must be in the “ON” position to allow fuel to flow so that the engine can run. Turn the Air Vent to the “OFF” position to stop fuel flow.

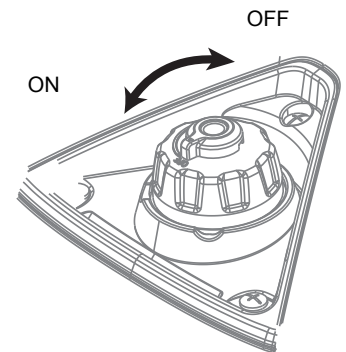

Ground Terminal

The generator’s ground terminal must always be used to connect the generator to a driven ground rod. Connect the ground terminal to the driven ground rod with a No 8 AWG (American Wire Gage) copper wire. The wire connects to the terminal between the lock washer and nut. Tighten the nut securely to ensure good connection. Grounding the generator protects you from electric shock that results from a build up of static electricity or undetected ground faults.

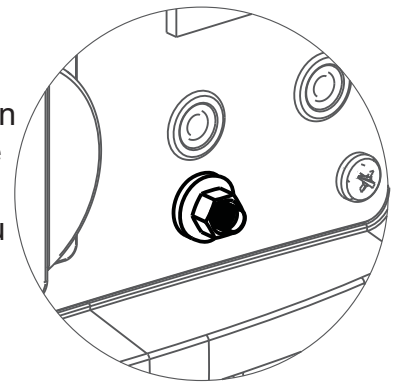

WARNING



Generator must be properly grounded to prevent electrocution.

- Only operate generator on a level surface.
- Always connect the nut and ground terminal on the frame to an appropriate ground source.

ASSEMBLY

Connecting Generator to an Electrical System

- If connecting generator to a building's electrical system for standby power, you must use a qualified electrician to install a transfer switch. The power from the generator must be isolated from the circuit breaker or alternative power source. The connection must comply with all electrical codes and applicable laws.

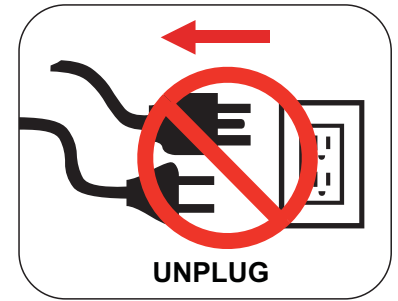

Never directly connect generator to a household power source.

WARNING



This generator produces a very high voltage which could result in burn or electrocution causing serious injury or death.

- Never handle the generator, electronic devices, or any cord while standing in water, while barefoot, or when hands or feet are wet.
- Always keep the generator dry. Never operate generator in rain or under wet conditions.
- Use a ground fault circuit interrupter (GFCI) in a damp or highly conductive area, such as metal decking or steel work.
- Never plug electronic devices into generator having frayed, worn, or bare wires. Never touch bare wires or make contact with receptacles.
- Never permit a child or unqualified person to operate generator. Keep children a minimum of 10 feet away from the generator at all times.
- If using the generator for back up power, notify the utility company.
- If connecting generator to a building's electrical system for standby power, you must use a qualified electrician to install a transfer switch. Failure to isolate the generator from the power utility could result in serious injury or death to electric utility workers.

Adding Fuel

- Set generator on a clean and level surface in an area that is well ventilated.
- Remove fuel cap.
- Insert the funnel into the fuel tank and carefully pour in commercially available unleaded gasoline containing no more than 10% ethanol (E10) until the fuel level is about 1½ inches below the tank's opening. Be careful not to overfill, leaving sufficient space for fuel expansion.
- Replace fuel cap and secure tightly.

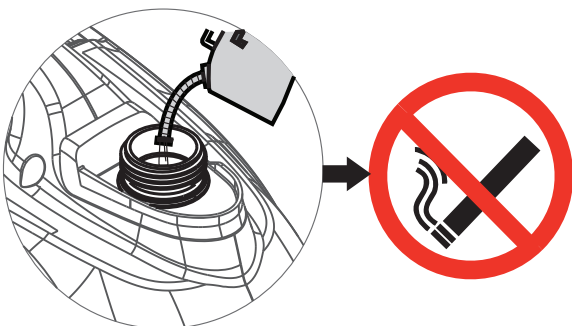
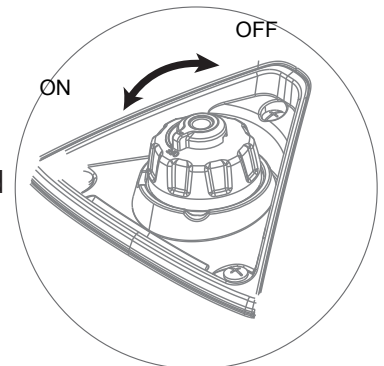

Do not smoke when adding fuel.

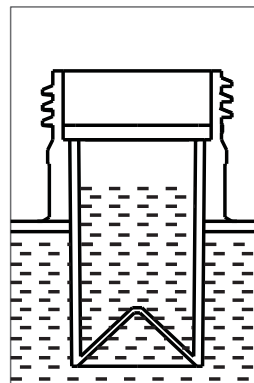

Do not overfill the tank to provide space for fuel expansion.

ASSEMBLY

Adding / Checking Engine Oil (See fig 4)

- Place generator on a level surface.
- Remove screws and then remove the outer casing cover.
(You must remove the spark plug cover to push the side panel off from the inside)

- Remove the crankcase dipstick.

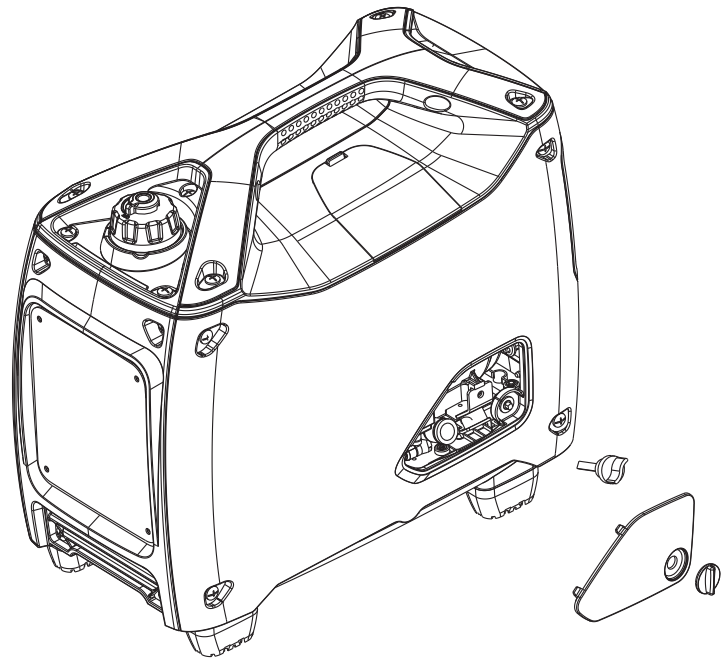

- Insert a funnel into the crankcase dipstick hole and carefully add the specified amount of 4-Cycle engine oil (SAE 10W-30) to empty reservoir until or oil reaches the outer edge of the oil fill hole (crankcase dipstick hole).
- Be sure to replace dipstick and securely tighten before attempting to start the engine.
- To check oil, set generator on a level surface, wipe dipstick clean, then reinsert dipstick without re-threading.

Recommended Oil: SAE 10W-30

Oil Capacity: 0.35L (0.924Gal)



Generator has been shipped without engine oil. You must add oil before first operating this generator. Always check oil level before each operation.

OPERATION

Grounding the Generator

To avoid electrocution, this generator must be properly grounded prior to use. For instructions see Control Panel Functions pg. 10.

Standard Atmospheric Conditions

Ambient Temperature: 77°F (25°C)

Barometric Pressure: 100kPa

Relative Humidity: 30%

Generator output will vary due to changes in temperature, altitude, and humidity. If the temperature, humidity, or altitude are higher than standard atmospheric conditions, the generator's output will be reduced. The load attached to the generator must therefore be reduced.

How to Start Engine

- Place generator on a level surface. All electrical loads **MUST** be disconnected from generator.
- Turn the ECO switch to "OFF"
- Turn the Air Vent to the "ON" position.
- Turn the 3 in 1 Start Switch to "CHOKE"
- Pull recoil handle (starter cord) slowly until resistance is felt, then pull rapidly.
- Let engine run for several seconds and then gradually, as engine warms up, turn the 3 in 1 Start Switch to the "ON" position.

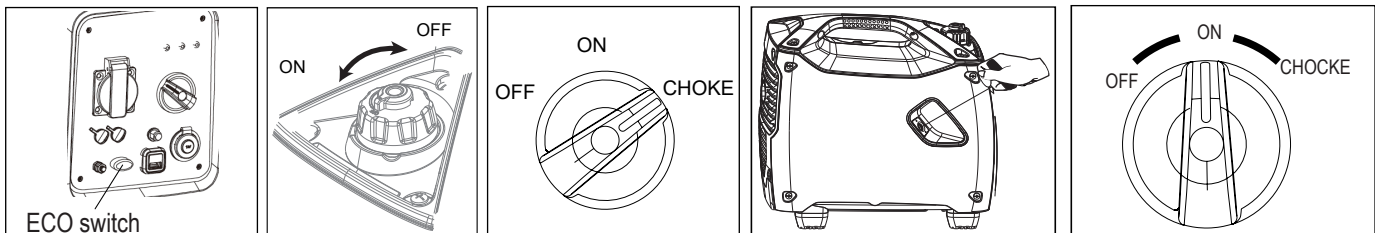

WARNING Pull cord recoils rapidly and pulls arm towards engine faster than you can let go which could result in injury.

- To avoid recoil, pull starter cord slowly until resistance is felt, then pull rapidly.

Note: To start the generator with the ECO switch in the "ON" position

- Disconnect all electrical loads from generator.
- If ambient temperature is below 32°F (0°C) allow 3 minutes for the engine to warm up.
- The ECO is in "ON" position, the unit returns to normal operation after the above warm up time.
- ECO switch must be turned to the "OFF" position when using electronic devices that require a large starting current, such as a compressor.

OPERATION

How to Stop Engine

- Turn the ECO switch to the “OFF” position.
- Disconnect any electronic device. All loads **MUST** be disconnect from the generator. Never start or stop the engine with electrical devices plugged in to the receptacles.
- Turn the 3 in 1 Start Switch to the “OFF” position.
- Turn the Air Vent to the “OFF” position.

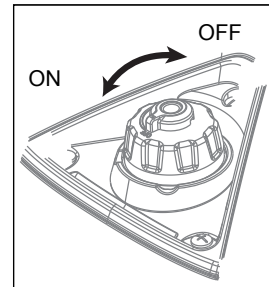
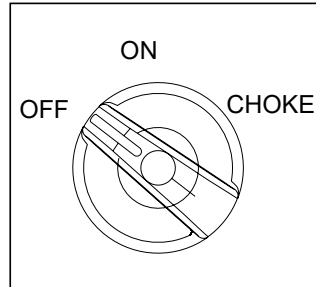
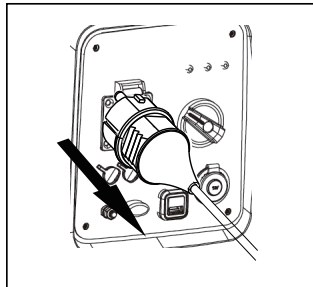
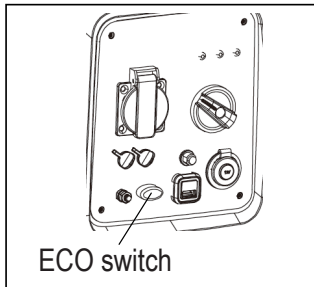

WARNING

Never start or stop engine with electrical devices plugged in to the receptacles. Failure to do so could damage the generator and / or connected electrical devices.

- Always start the engine and let it stabilize before connecting any electronic devices.
- Disconnect all electronic devices before stopping the engine.

How to Attach Electronic Devices

1. Before Starting generator

- Make sure the generator is grounded (see page 10 for instructions).
- Make sure the attached load is within the generator rated output and the receptacle's rated current.
- Make sure all electrical cords and receptacles are in good condition.
- Make sure all electronic devices are turned “OFF” before plugging them into the generator.

2. Start engine

3. If the attached load is small, turn the ECO switch to the “ON” position. For a larger load, or if attaching multiple electronic devices turn the ECO switch to the “OFF” position.
4. Make sure the green AC pilot indicator light is on.
5. When engine has stabilized, plug in and turn on first load. It is strongly recommended to plug in devices with the largest output first and the smallest output last to help prevent overloading the generator.
6. Allow generator output to stabilize (engine and attached devices run evenly) before plugging in the next load.

OPERATION

AC Parallel Operation

The D2000iS generator has two models that are compatible with each other (Standard and Companion). It is possible to connect two D2000iS generators to each other, using a parallel cable kit.

- Connect PARALLEL OPERATION CABLES to two D2000iS generators according to the instructions provided with the cable kit.
- Make sure the ECO switch is in the same position on both generators.
- All electronic devices should be turned “OFF” and disconnected from generators prior to starting generator engines.
- Start generator engines. Make sure the green output indicator light comes on for each generator.
- When engine has stabilized, plug in electronic device to AC receptacle and turn on first load.
- Allow generator output to stabilize (engine and attached devices run evenly) before plugging in the next load.

Maximum Power in Parallel Operation: 4.0kVA

Rated Power in Parallel Operation: 3.0kVA

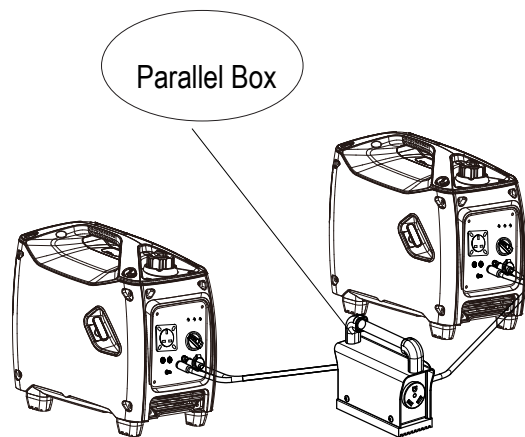

Note: It is strongly recommended to plug in devices with the largest output first and the smallest output last to help prevent overloading the generator.

Note: Most electronic devices require power beyond its rated wattage to start. This additional power is referred to as surge watts and usually lasts between 2-3 seconds. When an electronic device is started, the red overload indicator may come on. This is normal. If the light stays on disconnect all electronic devices and stop the engine. Refer to “Engine Overload Indicator Light” on page 8.



WARNING

Only connect electronic devices to the generator that are in good working order and do not exceed the rated power supply of the parallel generators or the desired receptacle.

- A faulty appliance or power cord can create an electric shock. Do not use electronic devices that have a damaged cord or plug.
- If an appliance begins to operate abnormally, becomes sluggish, or stalls, turn off and disconnect appliance immediately. The appliance may have a fault or its rated load capacity exceeds the power supply of the generator.
- To avoid damage to generator or electronic device, do not connect a load to the generator if its electrical rating exceeds that of the receptacle.



WARNING

Never connect generators that are different models.

- Only connect this generator to another D2000iS Generator or D2000iS Companion Generator
- Only use brands approved parallel operation cable kit to connect generators.
- The parallel cable must be removed if operating only one generator.
- Never disconnect or remove the parallel operation cable while generator is still running.

OPERATION

Don't Overload Generator

Make sure you can supply enough rated watts for all electronic devices connected to the generator. Rated watts refer to the power a generator must supply to keep a device running. Surge watts refer to the power a generator must supply to start an electronic device. This power surge for starting a device usually lasts between 2-3 seconds but this additional output must be taken into account when selecting the electronic devices you plan to attach to the generator. To prevent overloading the generator take the following steps:

1. Add up the total rated wattage of all electronic devices that will be connected to the generator simultaneously.
2. Estimate surge watts by adding the item(s) with the highest output (it is unnecessary to calculate the surge output for all devices as they should be connected one at a time).
3. Add the Surge Watts to the total Rated Watts in step 1. Keep total load within generator's power capacity.

Wattage Reference Guide

(Wattages listed are just approximations. Check electronic device for actual wattage)

Essentials	Rated Watts	Surge Watts
75W Light Bulbs	75 each	75 each
18 CU Ft Refrigerator / Freezer	800	2200
Furnace Fan (1/3 HP)	800	2350
Sump Pump (1/3 HP)	1000	2000
Water Pump (1/3 HP)	1000	3000
Heating/Cooling		
Dehumidifier	650	800
Table Fan	800	2000
Electric Blanket	400	400
Space Heater	1800	1800
Kitchen		
Blender	300	900
Toaster (2 slice)	1000	1600
Coffee Maker	1500	1500
Electric Range (1 element)	1500	1500
Dishwasher	1500	3000
Laundry Room		
Iron	1200	1200
Washing Machine	1150	3400
Gas Clothes Dryer	700	2500

Bathroom	Rated Watts	Surge Watts
Hair Dryer	1250	0
Curling Iron	1500	0
Family Room		
X-Box or Play Station	40	0
AM/FM Radio	100	100
VCR	100	100
Color TV (27")	500	500
Home Office		
Fax Machine	65	0
Personal Computer (17" Monitor)	800	0
Laser Printer	950	0
Copy Machine	1600	0
Power Tools		
1000W Quartz Halogen Work Light	1000	0
Airless Sprayer (1/3 HP)	600	1200
Reciprocity Saw	960	0
Circular Saw (7 1/4")	1400	2300
Mitar Saw (10")	1800	1800
Table/Radial Arm Saw	2000	2000
Electric Drill (1/2 HP, 5.4 Amps)	600	900

MAINTENANCE

Regular maintenance will extend the life of this generator and improve its performance. The warranty does not cover items that result from operator negligence, misuse, or abuse. To receive full value from the warranty, operator must maintain the generator as instructed in this manual, including proper storage.



WARNING

Before inspecting or servicing this machine, make sure the engine is off and no parts are moving. Disconnect the spark plug wire and move it away from the spark plug.



CAUTION

If you are unsure of how to perform a maintenance task, have the unit serviced by our dealers.



CAUTION

Only use our specified replacement parts.

Maintenance Schedule

Pre-Operation Steps

Before starting the engine, perform the following pre-operation steps:

- Check the level of the engine oil and the fuel tank level. Check for any leakage.
- Check fuel hose for cracks or damage. Replace if necessary.
- Make sure the air filter is clean.
- Remove any debris that has collected on the generator and around the muffler and controls. Use a vacuum cleaner to pick up loose debris. If dirt is caked on, use a soft bristle brush.
- Inspect the work area for hazards.

After Each Use

Follow the following procedure after each use:

- Shut off engine.
- Store unit in a clean and dry area.

After First 5 Hours	Change Oil.
After 8 Hours or Daily	Clean Debris.
	Check Engine Oil Level.
6 Months (100 hr Use)	Check and Clean Air Filter Element. (Service more often under wet or dusty conditions.)
	Change Engine Oil. (Service more often under dirty or dusty conditions.)
	Check Muffler Screen. Replace if necessary.
	Service Spark Plug.
	Inspect Muffler and Spark Arrester.
12 Months (300 hr Use)	Clean Fuel Filter. Replace if necessary.
	Check Crankcase Breather Hose for cracks or damage. Replace if necessary.
	De-carbonize cylinder head. See dealer.
	Check and adjust Valve Clearance. See dealer.
	Check all Fittings and Fasteners. See dealer.

MAINTENANCE

Checking Spark Plug

- Remove cap. Then remove spark plug cap.
- Disconnect the spark plug wire from the spark plug.
- Before removing the spark plug, clean the area around its base to prevent debris from entering the engine.
- Insert a spark plug socket wrench through the opening on the outside of the cover. Turn the wrench counterclockwise.
- Check for discoloration and clean carbon deposits off the electrode with a wire brush.
- Check the electrode gap and slowly adjust to 0.7 - 0.8mm (0.028-0.031 in) if necessary.
- Reinstall spark plug and tighten to Torque 20.0Nm (14.8ft-lb).
- If spark plug is worn replace only with an equivalent replacement part. Spark plug should be replaced annually.
- Reconnect spark plug wire.
- Replace spark plug cap, then replace cap.

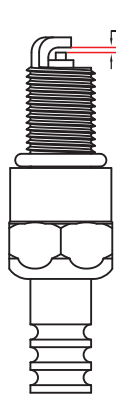

Standard Spark Plug: E6RTC

Spark Plug Gap: 0.7 - 0.8mm (0.028-0.031 in)

Spark Plug Torque: 20.0Nm (14.8ft-lb)

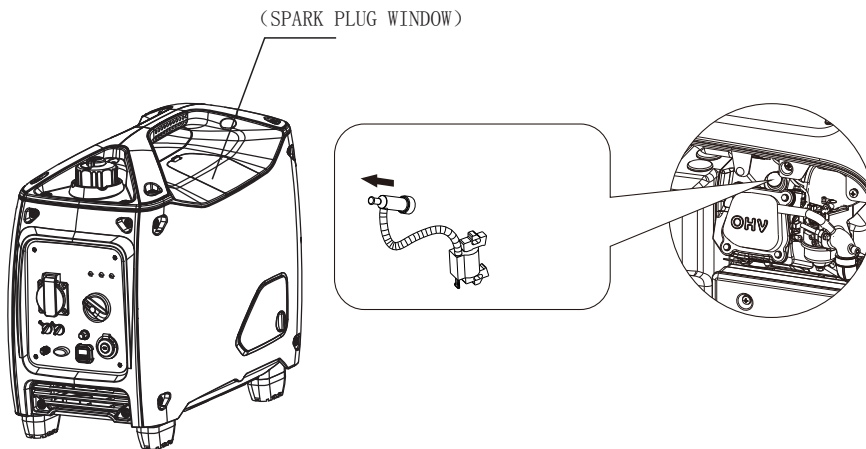

Carburettor Adjustment

The carburettor is low emission and is equipped with a non-adjustable idle mixture valve. If adjustment is needed contact SGS Engineering at 01332 576 850.

MAINTENANCE

Changing Oil

- Place generator on a level surface.
- Run the generator for several minutes until the engine is warm. Turn off generator.
- Remove screws, then remove outer casing.
- Remove the crankcase dipstick.
- Place an oil pan underneath the engine. Tilt generator to collect used oil. Allow oil to drain completely.
- Return generator to a level surface.
- Carefully add 4-Cycle engine oil (SAE 10W-30) to empty reservoir until oil reaches the outer edge of the oil fill hole (Crankcase Dipstick hole).
- Use a clean rag to wipe up any spilled oil.
- Replace crankcase dipstick.
- Reinstall outer casing and tighten screws.

Recommended Engine Oil: SAE 10W-30

Recommended Engine Oil Grade: API Service SE type or higher quality of engine oil.

Engine Oil Quantity: 0.35L (0.924 US gal)

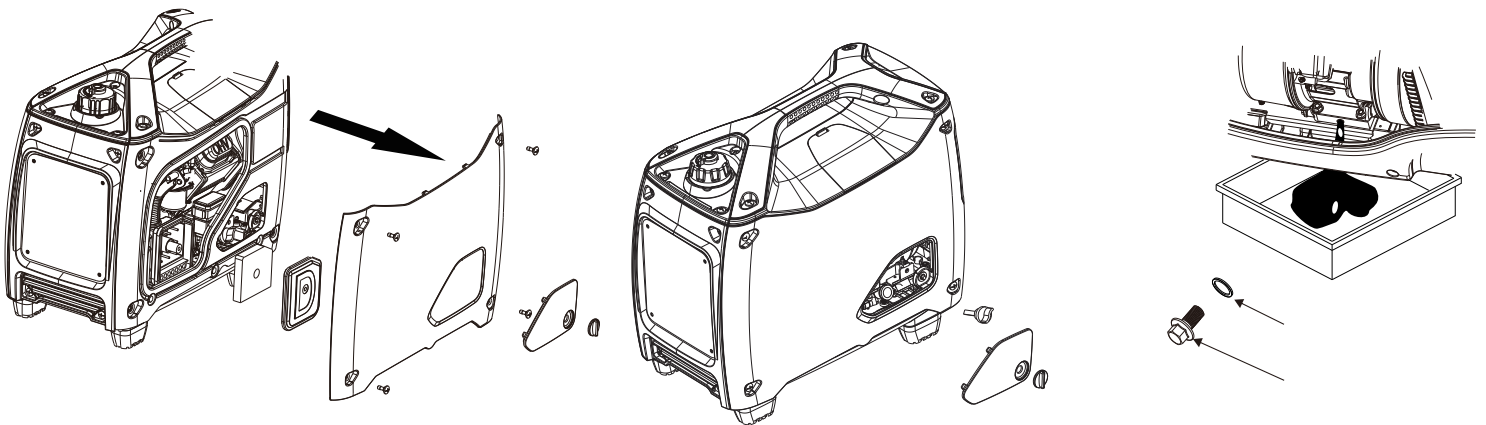

CAUTION

Do not tilt generator when adding oil. This could result in overfilling which could damage the engine.



CAUTION

Make sure no foreign matter enters the crankcase

MAINTENANCE

Air Filter

A dirty air filter will reduce the life span of the engine, make it difficult to start the engine, and reduce the unit's performance. Replace with new filter annually.

- To clean, remove the screws then remove outer casing.
- Remove the screws then remove air filter cover.
- Remove the foam element.
- Wash the foam element in solvent and let dry.
- Pour a small amount of oil on the foam element then squeeze out, but do not wring out, excess oil. Foam element should be damp, but not dripping.
- Reinsert the foam element into the air filter case.

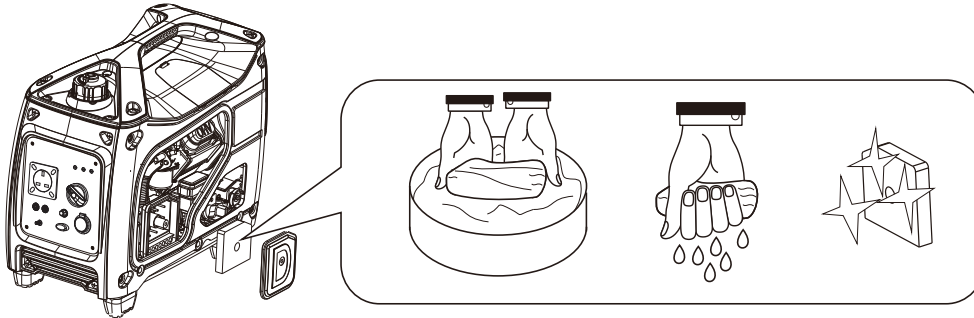
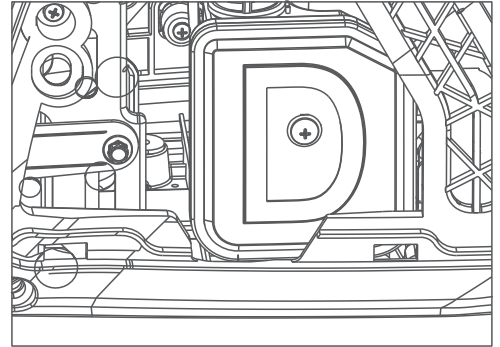

CAUTION

Do not run the generator without reinstalling the foam element or excessive piston and cylinder wear may result.

Checking Muffler and Spark Arrester

- Inspect muffler for cracks, corrosion, or other damage.
- Remove screws, then remove shown area of outer casing.
- Loosen bolt, then remove muffler cap, muffler screen, and spark arrester.
- Check the muffler screen and spark arrester for carbon deposits. Remove carbon deposits with a wire brush.
- Check the muffler screen and spark arrester for damage. If damaged replace with Our replacement parts specifically designed for this unit.
- Install the spark arrester. Align the spark arrester projection with the hole in the muffler pipe.
- Install the muffler screen and muffler cap.
- Install the outer casing and tighten the screws.

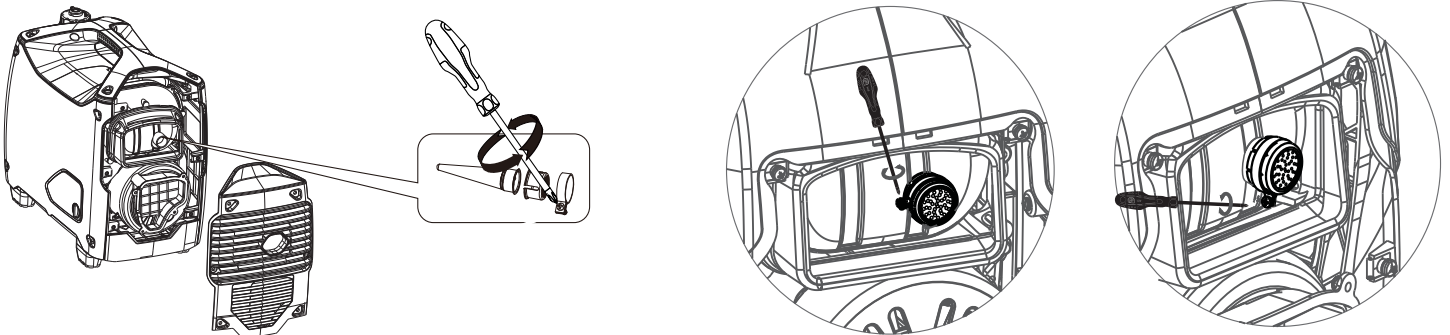

WARNING



Avoid contacting hot areas of this unit.

- Use caution around the muffler, cylinder, and other engine parts as they can be extremely hot.
- Allow hot components to cool before touching.

MAINTENANCE

Fuel Tank Filter

- To clean, remove fuel cap and filter.
- Clean filter with gasoline.
- Wipe the filter with a clean rag.
- Install filter.
- Install fuel cap.

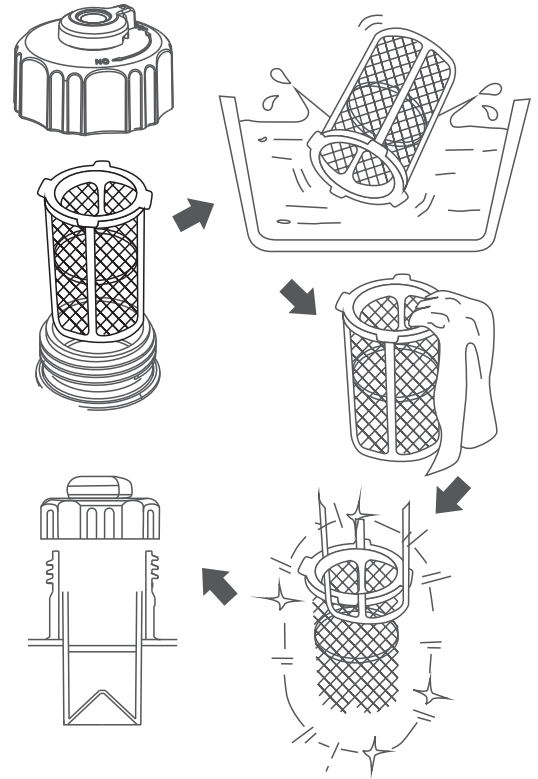

Fuel Filter

- To clean, remove screws, remove outer casing, and drain fuel.
- Lift and hold onto the clamp, then remove hose from tank.
- Take out fuel filter.
- Clean filter with gasoline.
- Wipe the filter with a clean rag and return filter to tank.
- Install hose and clamp.
- Open fuel valve. Inspect for leakage.
- Install outer casing and tighten screws.

Storage

To protect your generator from deterioration during long term storage, take the following preventative measures:

EXTERIOR

- Remove any debris that has collected on the generator and around the muffler and controls. Use a vacuum cleaner to pick up loose debris. If dirt is caked on, use a soft bristle brush.
- Inspect air cooling slots. Remove any debris if obstructed.
- Store indoors and use a protective cover to protect from dust.

FUEL

- Ethanol-blended fuel (E10) has poorer stability and tends to degrade over time. It is recommended that fuel in the tank not be left idle for more than one month. If long-term storage is necessary, you can run the generator until the fuel is completely consumed and the engine shuts down automatically, thereby draining the carburetor.

ENGINE

- Remove spark plug. Pour about 1 TBL of SAE 10W-30 engine oil into the spark plug hole, then reinstall spark plug.
- With the 3 in 1 switch in the "OFF" position, pull the recoil starter several times to coat cylinder walls with oil.
- Slowly pull the recoil starter until you feel the engine build compression (when you feel resistance). Leave the engine in this state. This will help prevent rust build up in the cylinder walls.

MAINTENANCE

How to drain fuel

- Turn the 3 in 1 switch to the “OFF” position.
- Remove fuel cap and fuel tank filter.
- Use a siphon to transfer gasoline from generator into a gasoline approved container.
- Wipe up any spilled fuel with a clean rag.
- Start generator engine and let it run until it stops and all remaining fuel is consumed. Do not connect electronic devices to generator during this process.
- Remove outer casing screws, then remove outer casing.
- Drain fuel from carburetor by loosening the drain screw on the carburetor float chamber.
- Turn the 3 in 1 switch to “OFF”
- Tighten the drain screw.
- Install the outer casing and tighten screws.
- When the engine has completely cooled down, turn the Fuel Cap Air Vent to the “OFF” position.

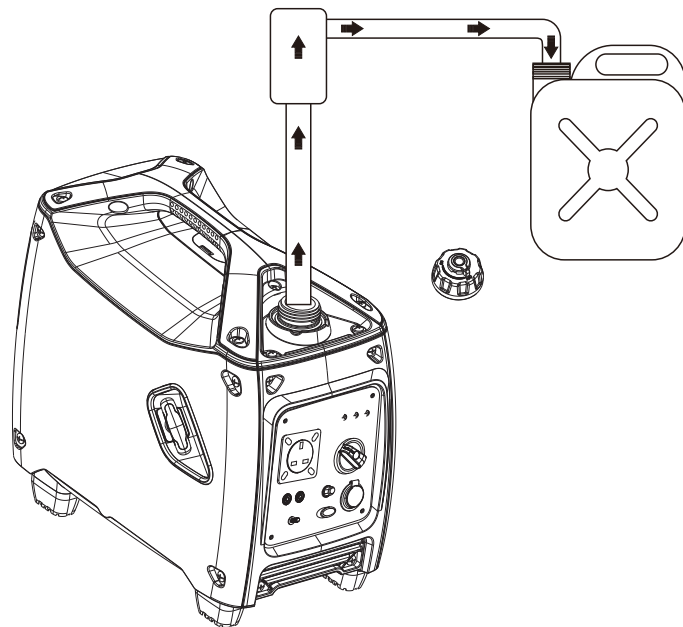
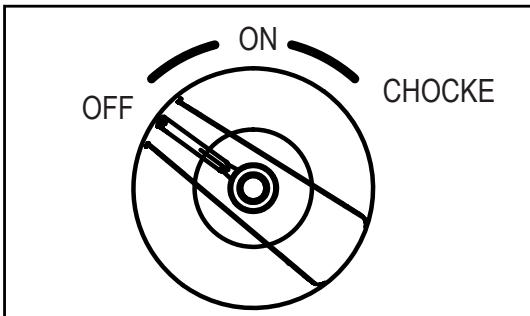

TROUBLESHOOTING

Problem	Cause	Solution
Generator is running, but does not supply power.	<ol style="list-style-type: none"> 1. DC Circuit Breaker is "OFF" 2. Green AC Pilot Light Indicator is off. 3. Poor connection 4. Defective cord set 5. Connected device is faulty 6. Fault in generator 	<ol style="list-style-type: none"> 1. Turn DC Circuit Breaker "ON" 2. Stop engine and restart. 3. Check and repair 4. Check and repair 5. Connect a device that is working properly 6. Contact service department
Engine runs good without load but bogs down when loads are connected	<ol style="list-style-type: none"> 1. Short circuit in connected device 2. Generator is overloaded 3. Clogged fuel filter 4. Engine speed is too slow 5. Short circuit in generator 	<ol style="list-style-type: none"> 1. Disconnect device 2. See pg 17 "Don't overload generator" 3. Clean or replace fuel filter 4. Contact service department
Engine will not start, shuts down during operation, or starts and runs rough.	<ol style="list-style-type: none"> 1. 3 in 1 switch set to "OFF" 2. Dirty Air filter 3. Clogged fuel filter 4. Out of fuel or Stale fuel 5. Spark plug wire disconnected from spark plug 6. Bad spark plug 7. Water in fuel 8. Overchocking 9. Low oil level 10. Engine has flooded 11. Faulty ignition 	<ol style="list-style-type: none"> 1. Turn switch to "CHOKE" then pull recoil starter. 2. Clean or replace Air filter 3. Clean or replace fuel filter 4. Replace fuel 5. Reconnect spark plug wire 6. Clean or replace spark plug 7. Drain fuel tank and replace fuel 8. Turn off choke 9. Add oil level. 10. Wait 5 minutes and re-crank engine 4. Contact service department
Engine lacks power	<ol style="list-style-type: none"> 1. Generator is overloaded 2. Clogged fuel filter 3. Dirty Air filter 4. Engine needs servicing 	<ol style="list-style-type: none"> 1. See pg 17 "Don't overload generator" 2. Clean or replace fuel filter 3. Replace Air filter 4. Contact service department
Engine "hunts" or falters	<ol style="list-style-type: none"> 1. Choke was removed too soon 2. Clogged fuel filter 3. Carburettor is running too rich or too lean 	<ol style="list-style-type: none"> 1. Move to choke until engine runs evenly 2. Clean or replace fuel filter 3. Contact service department



EC DECLARATION OF CONFORMITY



For the following machinery:

- Product name: Gasoline Engine Generator
- Commercial name: Gasoline Engine Generator
- Function: Low-power generating set
- Type: Gasoline
- Model No.: SIG2000
- Serial No.:

is herewith confirmed to fulfill all the relevant provisions of

- Machinery Directive (2006/42/EC)

and the following harmonized standard have been complied with:

- EN ISO 8528-13:2016

is herewith confirmed to fulfill all the relevant provisions of

- Electromagnetic Compatibility Directive (2004/108/EC)

and the following harmonized standard have been complied with:

- EN 61000-6-1:2019; EN 55012:2019+A1

is herewith confirmed to fulfill all the relevant provisions of

- Noise Emission Directive by equipment for use outdoors (2000/14/EC + 2005/88/EC)

Conformity Assessment Procedure: 2000/14/EC, amended by 2005/88/EC- Annex VI

- Measured Sound Power Level – LwA 91dB(A)
- Guarantee Sound Power Level – LwA 91dB(A)

Responsible for marking this declaration is the

Manufacturer's Name : SGS Engineering (UK) Ltd

Manufacturer's Address : 1 West Side Park, Belmore Way, Raynesway, Derby DE21 7AZ

Person responsible for making this declaration

Name, Surname P^AÙa • [{
 Position/Title ÔÒU
 Place Ö^!à` ÈNS
 Date GEG@p [ç^ { à^! / GEG



(CEO Signature)